

- 1) Landing door
- 2) Cabin
- 3) Guide rails
- 4) Shaft wall from reinforced concrete
- 5) Power cabinet (max 20 m from the shaft)

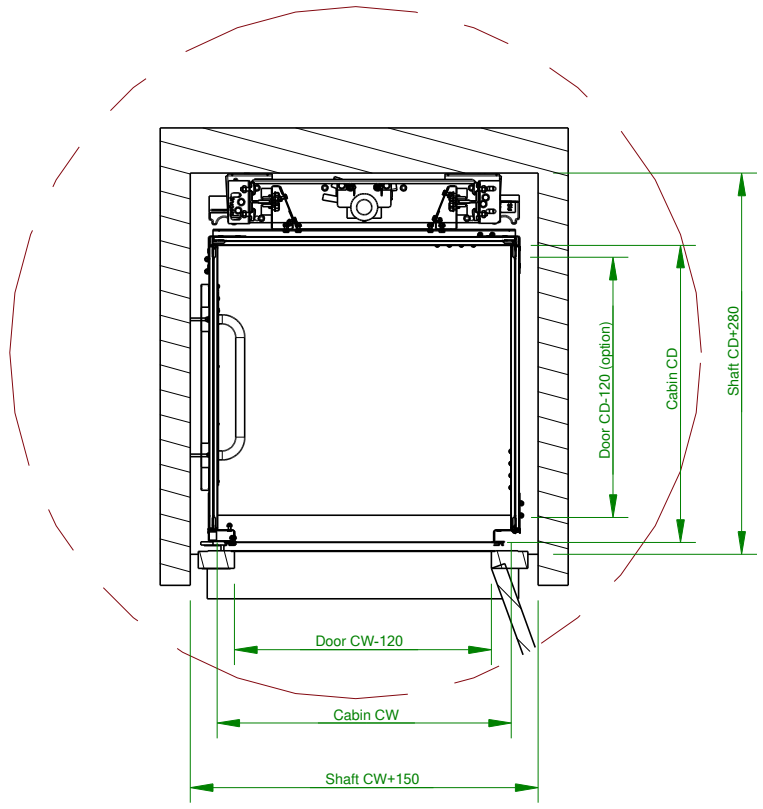
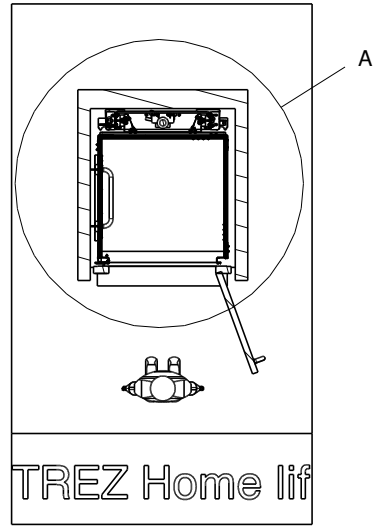

Model	Max load	Cabin wide CW	Cabin Deep CD	Power
TREZ Home 350	350 kg	min 700 mm, max 1300 mm	min 800, max 1300 mm	0.8 kW , 230 VAC
TREZ Home 450	450 kg	min 700 mm , max 1400 mm	min 900, max 1400 mm	1.1 kW , 230 VAC

Itemref	Quantity	Title/Name, designation, material, dimension etc	Article No./Reference		
Drawn by	Checked by	Approved by - date	File name	Date	Scale
TREZ home lift Speed 0.13 m/s Power supply 230 VAC 10 A 2006/42/EC Certifications			TREZ Home lift		
			Edition	Sheet	